

Bakfiets.nl



has changed the look of cycling in the Netherlands, United Kingdom and many other countries. Their concept of carrying children in a cargo bike was innovative and is now accepted world-wide as an alternative and green form of transport. For many parents using a Bakfiets.nl Cargobike or Cargotrike is a liberating and life changing experience especially on the school run in busy towns and cities where the volume of traffic has become a big problem. Since the first model, there has been continuing development to enable you to carry babies, children, dogs, shopping and cargo with ease and in safety.

→ Electric Assist

Almost all CargoBikes and Trikes are available with an electric driven assist motor. This makes cycling more comfortable (lighter and faster). The motor can also be used to assist you while pushing the bike.

The battery can be placed in the rear rack or mounted on the box and is removable.

→ Shimano STEPS

All the Cargobikes and Trikes make use of the Shimano Steps (DU6100). This powerful motor is light and reliable, and is located at the bottom bracket. The motor has a good range and long battery life. The handlebar mounted display is simple to use and has a handlebar mounted toggle switch to change between the functions and power settings. There is even a walk function for pedestrianised areas when dismounted.

Available gear options

Steps is available in combination with different gear options: Sram Duomatic 2 speeds auto change hub with Shimano rollerbrakes, Shimano Nexus 7 speed with Rollerbrakes, Shimano Di2 8 speed hub with electronic gear changer and the Shimano rollerbrakes NuVinci continuously variable hub gear with rollerbrakes

Di2

The Di2 version is fully integrated with the motor and by means of electronic control the motor automatically reduces power slightly to enable smooth electronic gear shifting. The system automatically shifts down when coming to a halt therefore you are in the right gear to set off again. Or you can choose to manually select the gears with the toggle switch on the handlebar.

Automatic Shifting

The combination of our drive unit and the Di2 internal gear hub enables you to use the fully automatic shifting function. Torque, speed and cadence are monitored to automatically and smoothly shift to the right gear. You can switch back to manual shift whenever you want.

→ Operating Range

Pay attention: for a Cargobike its hard to specify the exact operation range. The operation range can vary between 25 km and 70 km (15 and 50 miles). This depends on the total weight (rider + load) of the Cargobike, the level of assistance chosen from the motor. The terrain to be covered—flat—hilly or mountainous. City or country environments will have a big influence, stopping and starting especially. Its possible to increase the operation range by driving away in a low gear and by making sure that the tires are inflated.

We deliver the bikes standard with a 418Wh battery, optionally there can be chosen for the upgraded 500Wh version, which has a 20% larger operating range.

Motor unit

Weighs 3.2 kilos and has intelligent assistance for a natural feel.

Accu

36 Volt weight: 2,55 kg.
Also sold independently:
418 Wh
500 Wh

Display

Standard bike functions, range, battery condition and for Di2 version gear indication.

Charger

Can fully charge the battery in only 4 hours.

Toolkit

Gives information about: speed, distance, estimated range, battery condition and support status.

Operating switch





→ CargoBike Classic Short Steps

The Cargobike classic short Steps is a traditional CargoBike with the Shimano Steps motor. The motor is mounted in the bottom bracket and the removable battery is integrated in the carrier. The motor detects rotation, cadance and torque to give you smooth power assistance.

Dimensions Cargobike short: length 228cm x width 63cm.



Colours: gloss black / petrol blue / matt granite



→ Available gear options

Rollerbrakes:

Sram 2v:
Shimano 7v:
Shimano 8v Di2:

NN2
NN7
NN8

Disc brakes:

Shimano 7v:
Shimano 8v:
Enviolo

SS7
SS8
SSi

Magura HS11 rim brakes:

Shimano 7v:
Shimano 8v Di2:
Enviolo:

MM7
MM8
MMi



→ Accessories (See page. 26 to 29)





→ CargoBike Cruiser Short Steps

A vintage version similar to the CargoBike Classic Steps, but with fat tyres for comfort, broad mudguards in matching frame colour, Brooks Aged leather saddle and handlebar grips, a retro style 35 lux headlight and Plateo rear light. The battery is mounted on the back of the wooden box.

Dimensions Cargobike short: Length 228cm x width 63cm



Colours: gloss black / petrol blue / matt granite



→ Available gear options

Rollerbrakes:

- Sram 2v:
- Shimano 7v:
- Shimano 8v Di2:

- NN2**
- NN7**
- NN8**

Disc brakes:

- Shimano 7v:
- Shimano 8v:
- Enviolo

- SS7**
- SS8**
- SSi**

Magura HS11 rim brakes:

- Shimano 7v:
- Shimano 8v Di2:
- Enviolo:

- MM7**
- MM8**
- MMi**

→ **Accessories**
(See page. 26 to 29)





→ CargoBike Classic Long Steps

The Cargobike classic short Steps is a traditional CargoBike with the Shimano Steps motor. The motor is mounted in the bottom bracket and the removable battery is integrated in the back of carrier rack. The motor detects rotation, cadance and torque to give you smooth power assistance. Due to the longer box there is more space available for accessories such as the Maxi-Cosi or an extra bench.

Dimensions Cargobike long: length 253cm x width 63cm.



Colours: matt black / petrol blue / matt granite / ivory / bright red / deep oragne / matt army green



→ Available gear options

Rollerbrakes:

Sram 2v:
Shimano 7v:
Shimano 8v Di2:

NN2
NN7
NN8

Disc brakes:

Shimano 7v:
Shimano 8v:
Enviolo

SS7
SS8
SSi

Magura HS11 rim brakes:

Shimano 7v:
Shimano 8v Di2:
Enviolo:

MM7
MM8
MMi

→ Accessories (See page. 26 to 29)





→ CargoBike Cruiser Long Steps

Similar to the CargoBike Classic Long Steps, but a vintage version with is broad mudguards in matching frame colour, Brooks Aged leather saddle and handlebar grips, a retro style 35 lux headlight and Plateo rear light. The battery is mounted on the back of the wooden box.

Dimensions Cargobike long: Length 253cm x width 63cm



Colours: matt black / petrol blue / matt granite / ivory / bright red / deep oragne / matt army green



Cargobike is shown with a black bok (extra charge).

→ Available gear options

Rollerbrakes:

Sram 2v:
Shimano 7v:
Shimano 8v Di2:

NN2
NN7
NN8

Disc brakes:

Shimano 7v:
Shimano 8v:
Enviolo

SS7
SS8
SSi

Magura HS11 rim brakes:

Shimano 7v:
Shimano 8v Di2:
Enviolo:

MM7
MM8
MMi



→ Accessories (See page. 26 to 29)

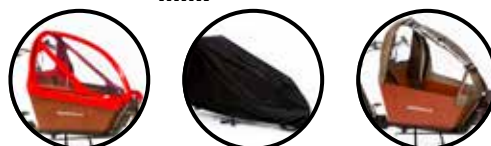



→ Shadow Steps

The Shadow is the top model from Bakfiets.nl. With its aluminum frame, Shimano Steps mid-engine, aluminum profile box with trampoline fabric. This model is the lightest and stiffest cargobike within our product range due to the aluminium double walled spiderweb tube in the frame. This makes cycling on this cargo bike a natural experience. The hydraulic brakes and strong rims make the Shadow a very stable and safe cargobike. The dimension of the box are equal to the CargoBike Long, so most accessories will fit.

Dimensions Shadow: length 253cm x width 63cm.



Colours: matt black / matt army green / matt granite



→ Available gear options

Magura rim brakes:

- Shimano 7v:
- Shimano 8v Di2:
- Enviolo:

- MM7**
- MM8**
- MMi**

Disc brakes:

- Shimano 7v:
- Shimano 8v Di2:
- Enviolo:

- SS7**
- SS8**
- SSi**



→ Accessories (See page. 26 to 29)







→ CargoTrike Classic Narrow Steps

The trike has more space than the Cargobike. There is standard room for four children. One of the benefits of the trike is the stability of the bike at lower speeds. **Take note that:** a lot of people still prefer the Cargobike due to the higher maneuverability of the bike.

Dimensions trike narrow: length 210cm x width 85 cm.
Dimensions bottom surface: length 86cm x width 54cm.



Colours: red / matt black / matt granite / petrol blue



→ Available gear options

Rollerbrakes:

- | | |
|-----------------|------------|
| Sram 2v: | NN2 |
| Shimano 7v: | NN7 |
| Shimano 8v Di2: | NN8 |

Disc brakes:

- | | |
|-----------------|------------|
| Shimano 7v: | SS7 |
| Shimano 8v Di2: | SS8 |
| Enviolo: | SSi |



→ **Accessories**
(See page. 26 to 29)





→ CargoTrike Cruiser Narrow Steps

The Cargotrike narrow cruiser is a trike with a modern “vintage” appearance due to its creme fat tires, retro style 35 lux headlights, Brooks Aged leather saddle and handlebar grips. All Trikes are equipped with a steering stabilizer. This provides stable steering and prevents sudden change of direction when one wheel hits a small pit.

Dimensions trike narrow: length 210cm x width 85 cm.
Dimensions bottom surface: length 86cm x width 54cm.



Colours: red / matt black / matt granite / petrol blue



→ Available gear options

Rollerbrakes:

Sram 2v:	NN2
Shimano 7v:	NN7
Shimano 8v Di2:	NN8

Disc brakes:

Shimano 7v:	SS7
Shimano 8v Di2:	SS8
Enviolo:	SSi



→ Accessories (See page. 26 to 29)





→ CargoTrike Classic Wide Steps

The wide version of the trike has a better road handling due to the bigger distance between the front weels. The bin also has a bigger capacity. There is also standard room for four children.

Dimensions trike wide: length 210cm x width 95 cm.
Dimensions bottom surface: length 86 cm x width 65 cm.



Colours: red / matt black / matt granite / petrol blue



→ Available gear options

Rollerbrakes:

Sram 2v:

Shimano 7v:

Shimano 8v Di2:

NN2

NN7

NN8

Disc brakes:

Shimano 7v:

Shimano 8v Di2:

Enviolo:

SS7

SS8

SSi

Option hint:

Order your Trike with an extremely good front disc brakes with parking brake.



→ Accessories (See page. 26 to 29)





→ CargoTrike Cruiser Wide Steps

The Cargotrike wide cruiser is a trike with a modern “vintage” appearance due to its creme fat tires, Brooks Aged leather saddle and handlebar grips and retro style 35 lux headlights. All Trikes are equipped with a steering stabilizer.

Take note off: In the cruiser trikes the battery is mounted in the carrier (this carrier is also compatible with a child seat).

Dimensions trike wide: length 210cm x width 95 cm.

Dimensions bottom surface: length 86 cm x width 65 cm.



Colours: red / matt black / matt granite / petrol blue



→ Available gear options

Rollerbrakes:

- Sram 2v: **NN2**
- Shimano 7v: **NN7**
- Shimano 8v Di2: **NN8**

Disc brakes:

- Shimano 7v: **SS7**
- Shimano 8v Di2: **SS8**
- Enviolo: **SSi**



→ Accessories
(See page. 26 to 29)





Bakfiets.nl

→ CargoBike XL

A CargoBike can be of great value for companies. Whether you work in parcel delivery, cleaning or maintenance, you'll always have your bike and tools close by as there's no hassle with parking. The CargoBike can be used as a marketing tool as well: it shows your company is green and flexible. On this page you'll find CargoBikes specially designed to carry whatever loads you need to transport.

The CargoBike XL is equipped with an extra long frame, so there is even more space for your goods. The XL can also be delivered with just a baseplate, so you can mount your own construction to fit your needs.

We also provide the XL with a simple rack or a complete flightcase, so you can start delivering your parcels right away.

Dimensions CargoBike XL: length 288cm x width 65cm.
 Dimensions base plate: length 102cm x width 42cm.
 Max load (driver included): 180kg



Colours: black

→ Available gear options

Without rack

- Shimano 7v with handbrakes
- Shimano 8v with handbrakes

NN7D
NN8D

With rack

- Shimano 7v with handbrakes
- Shimano 8v with handbrakes

NN7D
NN8D

With flightcase (*discontinued few items left)

- Shimano 7v with handbrakes
- Shimano 8v with handbrakes

NN7D
NN8D

→ Accessories (See page. 26 to 29)



→ CargoBike Classic Short

The CargoBike Classic Short is most similar to the original model, easy to steer, has a low centre of gravity and a wooden box where children can easily get in and out of. The unique four footed stand gives complete stability to the cargobike while loading and when parked. Also the magnetic safety belts are easy to use.

Dimensions Cargobike short: length 228cm x width 63cm.



Colours: gloss black / petrol blue / matt granite

→ Available gear options

Rollerbrakes:

Shimano 7v:

NN7D

Shimano 8v:

NN8D

Coaster brake with rollerbrake (front):

Shimano 8v:

NR8D

Magura HS11 rim brakes:

Shimano 7v:

MM7D

Shimano 8v:

MM8D

→ For the version with electric assistance see page 4 to 5.

→ Accessories
(See page. 26 to 29)



→ CargoBike Cruiser Short

The CargoBike Cruiser Short is a vintage version of the Classic model with fat tyres for comfort, broad mudguards in matching frame colour, Brooks Aged leather saddle and handlebar grips and a retro style 35 lux headlight and Plateo rear light (both powered by the hub dynamo and with standlight function). There is no rear carrier rack fitted.

Dimensions Cargobike short: Length 253cm x width 63cm



Colours: gloss black / petrol blue / matt granite



→ Available gear options

Rollerbrakes:

Shimano 7v: **NN7D**

Shimano 8v: **NN8D**

Coaster brake with rollerbrake (front):

Shimano 8v: **NR8D**

Magura HS11 rim brakes:

Shimano 7v: **MM7D**

Shimano 8v: **MM8D**

→ For the version with electric assistance see page 4 to 5.

→ **Accessories**
(See page. 26 to 29)



→ CargoBike Classic Long

The CargoBike Classic Long is identical to the Short but with a stretched frame and box. It has the space to carry up to 3 children by adding an extra bench at the front, or 2 children on the rear bench and a baby in a Maxi Cosi or white a woolly baby/toddler seat in the front area. You can also carry a dog with a top cage or add a door in the side of the box for easy entrance. In short, there are a lot of options available.

Dimensions Cargobike long: length 253cm x width 63cm.



Colours: gloss black / petrol blue / matt black / matt granite / ivory / matt blue



→ Available gear options

Rollerbrakes:

Shimano 7v:

NN7D

Shimano 8v:

NN8D

Coaster brake with rollerbrake (front):

Shimano 8v:

NR8D

Magura HS11 rim brakes:

Shimano 7v:

MM7D

Shimano 8v:

MM8D

→ For the version with electric assistance see page 6 to 8.

→ Accessories
(See page. 26 to 29)



→ CargoBike Cruiser Long

The CargoBike Cruiser Long is a vintage version of the Classic model with fat tyres for comfort, broad mudguards in matching frame colour, Brooks Aged leather saddle and handlebar grips and a retro style 35 lux headlight and Plateo rear light (both powered by the hub dynamo and with standlight function). There is no rear carrier rack fitted.

Dimensions Cargobike long: length 253cm x width 63cm.



Colours: gloss black / petrol blue / matt black / matt granite / ivory / matt blue



→ Available gear options

Rollerbrakes:

Shimano 7v: **NN7D**

Shimano 8v: **NN8D**

Coaster brake with rollerbrake (front):

Shimano 8v: **NR8D**

Magura HS11 rim brakes:

Shimano 7v: **MM7D**

Shimano 8v: **MM8D**

→ For the version with electric assistance see page 6 to 8.

→ Accessories
(See page. 26 to 29)



→ **CargoTrike Classic Narrow**

The trike has more space than the Cargobike, it also is more stable at lower speeds. There is standard room for four children due to the two included benches. There is also a handy step on top of the mudguards to help them get in and out of the box. As an accessory there is a user friendly tent and/ or pool cover available (in two colors).

Dimensions trike narrow: length 210cm x width 85cm.
Dimensions bottom surface: length 86cm x width 54.



Colours: gloss black / matt granite / petrol blue



→ **Available gear options**

Rollerbikes:

Shimano 7v:

NN7D

Shimano 8v:

NN8D

Coaster brake with rollerbrake (front):

Shimano 8v:

NR8D

→ **For the version with electric assistance see page 10 to 11.**

→ **Accessories**
(See page. 26 to 29)



→ **CargoTrike Cruiser Narrow**

The CargoTrike Cruiser Narrow is a vintage version of the Classic model with fat tyres for comfort, broad mudguards in matching frame colour, Brooks Aged leather saddle and handlebar grips and a retro style 35 lux headlight and Plateo rear light (both powered by the hub dynamo and with standlight function). There is no rear carrier rack fitted.

Dimensions trike narrow: length 210cm x width 85cm.
Dimensions bottom surface: length 86cm x width 54.



Colours: gloss black / matt granite / petrol blue



→ **Available gear options**

Rollerbakes:

Shimano 7v:

NN7D

Shimano 8v:

NN8D

Coaster brake with rollerbrake (front):

Shimano 8v:

NR8D

→ **For the version with electric assistance see page 10 to 11.**

→ **Accessories**
(See page. 26 to 29)



→ CargoTrike Classic Wide

The CargoTrike Classic Wide is similar in length to the Narrow, but is 10cm wider so it offers even more space for freight or children. As an accessory there is a pool cover and a wooden cover available. This makes the Cargotrike Wide perfect for transporting luggage.

Dimensions Trike Wide: length 210cm x width 95cm.
Dimensions bottom surface: length 86cm x width 65cm.



Colours: gloss black / matt granite / petrol blue



→ Available gear options

Rollerbikes:

Shimano 7v:

NN7D

Shimano 8v:

NN8D

Coaster brake with rollerbrake (front):

Shimano 8v:

NR8D

→ For the version with electric assistance see page 12 to 13.

→ Accessories
(See page. 26 to 29)



→ CargoTrike Cruiser Wide

The CargoTrike Cruiser Wide is a vintage version of the Classic model with fat tyres for comfort, broad mudguards in matching frame colour, Brooks Aged leather saddle and handlebar grips and a retro style 35 lux headlight and Plateo rear light (both powered by the hub dynamo and with standlight function). There is no rear carrier rack fitted.

Dimensions Trike Wide: length 210cm x width 95cm.
Dimensions bottom surface: length 86cm x width 65cm.



Colours: gloss black / matt granite / petrol blue



→ Available gear options

Rollerbakes:

Shimano 7v:

NN7D

Shimano 8v:

NN8D

Coaster brake with rollerbrake (front):

Shimano 8v:

NR8D

→ For the version with electric assistance see page 11 to 12.

→ Accessories
(See page. 26 to 29)





→ Riksja

Drivers and passengers can talk to each other comfortably and enjoy the surroundings in peace. The Riksja is a fantastic way to explore the city. This electric taxi is equipped with a Shimano Steps mid-engine. This makes it very durable and also much cheaper to use than a car (the battery is charged again for 10 cent!). The extendable footboard ensures that passengers can board safely. The Riksja is standard equipped with thick ventilating cushions. Optionally, the raincover and/or warm blanket can be ordered. The hood not only provides protection from the sun and rain, but also gives a cozy look.

Dimensions: Length 290cm x width 102cm



kleur: rood



→ Options Riksja STEPS

Enviolo Steps with disc brakes

SSi



Optional Raincover



Optional foot rug



Optional safety bracket





Safe disc brake



Front entry



Safe roll bars



Daycare

new

The Daycare trike can transport a maximum of six young children (age +/- 2 to 6 years). Its also possible to mount a child seat on the back carrier to transport one extra child. Take note that: how older/ taller the children are, the less space remains available. The bike has standard strong disc brakes, roll bars, two benches in the longitudinal direction and a front entry for the children



Colours: matt black / red / matt granite / petrol blue



→ Options Daycare trike

Enviolo Steps with disc brakes

SSI

Rail for high weight load:

Heavy loaded trikes can be fitted with a special rail system which also functions as a steering limitation. This special rail system is standard on the Riksja and Daycare (this option is also available for the wide versions of the trike)

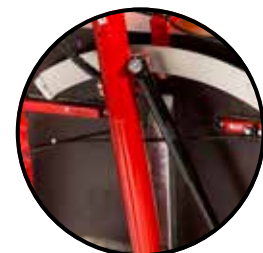

→ Accessories (See page. 26 to 29)



➔ Box options

Below you will find an overview of all the different box options we offer.
The business version is delivered without benches and seatbelts.

Standard

Business

Black box

Flightcase

Bottom plate

Aluminium

Short



Basis

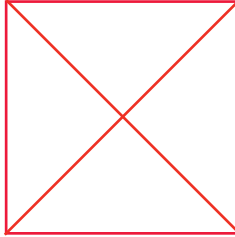
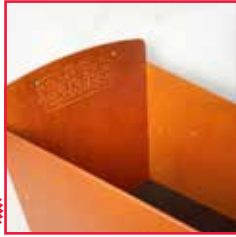

new

*Battery mounted in carrier

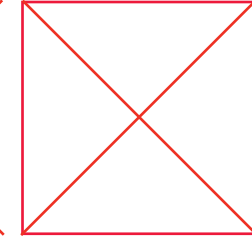
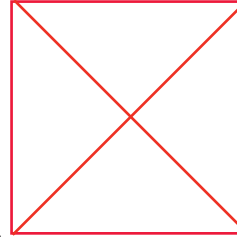

Long



Basis



*Battery mounted in carrier



Trike W



Basis



new



*Battery mounted in carrier

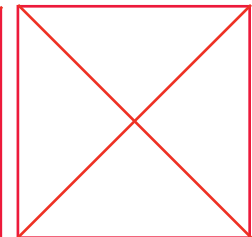
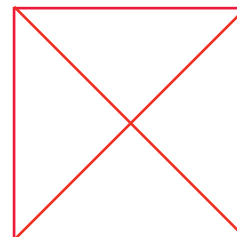

Shadow



Basis

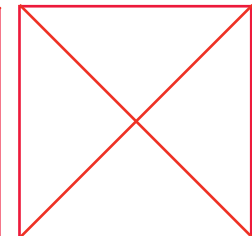
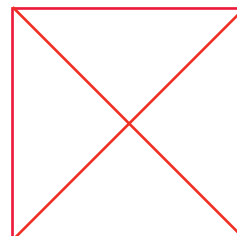
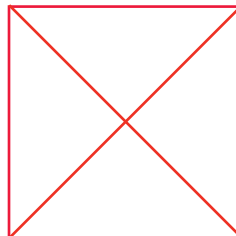

XL



Basis

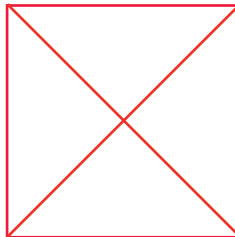
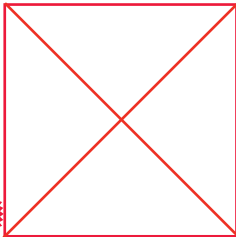

*Few items left

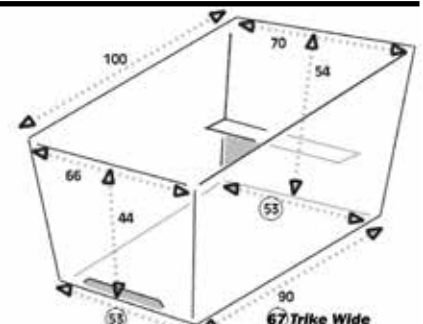
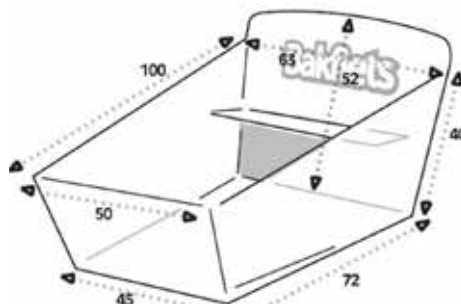
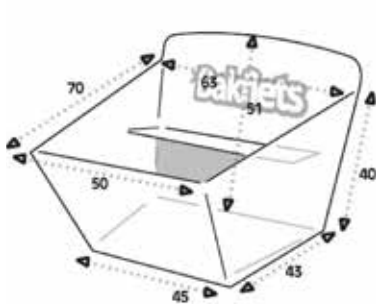
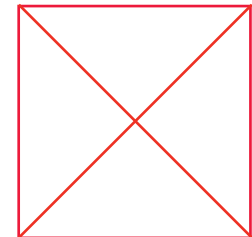

67 Trike Wide



*Discontinued few items left

➔ Options & Accessories

- 1 Ventisit cushion single with backrest
- 2 Ventisit cushion double with backrest
- 3 Thick single cushion black
- 4 Headrest
- 5 Maxi-cosi holder with bracket in box bottom
- 6 Maxi-cosi holder with brackets on bench
- 7 Black baby seat 0-9 months
- 8 Black toddler seat 9-18 months
- 9 Mounting bracket for baby / toddlerseat
- 10 Bracket for mounting front childseat on box bottom
- 11 Bracket for mounting front child seat on bench

Accessories CargoBike Short and Long

- 12 Eyelet for chain / cable lock
- 13 Extra seat on steerer tube
- 14 Sunshade (cargobike long and short)
- 15 Locker under bench redwood colour
- 16 Locker under bench black wood colour
- 17 Fold up rain tent supports (CargoBike short)
- 18 Fold up rain tent supports (CargoBike long)



➔ Options & Accessories

Accessories CargoBike Short

- 19 Flat box cover CargoBike short: black
- 20 Flat box cover CargoBike short: red
- 21 Flat box cover CargoBike short: crème
- 22 Rain tent CargoBike short: black
- 23 Rain tent CargoBike short: red
- 24 Rain tent CargoBike short: cream
- 25 Rain tent CargoBike short all-open: black
- 26 Rain tent CargoBike short all-open: tweed

Accessories CargoBike Long

- 27 Flat box cover CargoBike long: black
- 28 Flat box cover CargoBike long: red
- 29 Flat box cover CargoBike long: Tweed
- 30 Flat box cover CargoBike long: crème **Discontinued few items left*
- 31 Rain tent CargoBike long: black
- 32 Rain tent CargoBike long: red **Discontinued few items left*
- 33 Rain tent CargoBike long: cream
- 34 Rain tent CargoBike long: silver **Discontinued few items left*
- 35 Roll-up tent with folding supports
- 36 Extra 5cm high tent with zip sides: black
- 37 Extra 5cm high tent with zip sides: red
- 38 Extra 5cm high tent with zip sides: cream
- 39 Rain tent CargoBike long all-open: black
- 40 Rain tent CargoBike long all-open: tweed
- 41 Rain tent CargoBike long all-open: admiral blue
- 42 Rain tent CargoBike long all-open: matt black
- 43 Rain tent CargoBike long all-open: red
- 44 Rain tent CargoBike long all-open: brown
- 45 Flat box cover Shadow: matt black
- 46 Rain tent Shadow long all-open: matt black
- 47 Ventisit cushion double
- 48 Cushion double: tweed
- 49 Cushion double: admiral blue
- 50 Cushion double: matt black
- 51 Cushion double: red
- 52 Cushion double: brown
- 53 Door panel in the side of the box (without mounting)
- 54 Dog bench and cage for CargoBike long
- 55 Ventisit floor mat (reduces unwanted noises from the box)
- 56 All-over cover CargoBike long: Silver **Discontinued few items left*
- 57 All-over cover CargoBike long: Black (heavy duty quality)
- 58 Extra bench: redwood colour
- 59 Extra bench: black (no photo)
- 60 Reduced bench: black (children can sit lower in the box)

Accessories Trike

- 61 Flat box cover trike: black (fits Narrow and Wide)
- 62 Flat box cover trike: red (fits Narrow and Wide)
- 63 Rain tent Trike Narrow with zipper: black
- 64 Rain tent Trike Narrow with zipper: cream **Discontinued few items left*
- 65 Rain tent Trike Wide with zipper: black
- 66 Rain tent Trike Wide with zipper: tweed
- 67 Locker under bench trike (wide trike only (without mounting))
- 68 Box lid with gas damper (wide trike only) (without mounting)
- 69 All-over cover Trike (also fits over rain tent)
- 70 Ventisit floor mat trike wide (reduces unwanted noises from the box)
- 71 Cushion double with backrest





➔ **The best components**

Bakfiets.nl only uses the highest quality components available and works with the producers to get the best results, many of these parts are specially designed and made exclusively for us.



	Page	NN2 (rollerbrake F+R and 2 v automa ^t e)	NN7 (rollerbrake F+R and 7 speed hub)	NR8 (rol F and coaster R 8 speed hub)	NN8 (rollerbrake F+R and 8 speed hub)	MM7 (Magura hydro F+R and 7v hub)	MM8 (Magura hydro F+R and 8v hub)	MMi (Magura hydro F+R and Nuvinci hub)	SS7 (Discbrake F+R and 7v hub)	SS8 (Discbrake F+R and 8v hub)	SSi (Magura hydro F+R en Enviolo hub)	Steps electro engine, 418 Wh battery	A	B	C	D	E	F	G	H	I	J		
CargoBike Classic Short Steps	4	3389	3469	-	3745	3629	3905	3985	3699	3975	4055	v	179	v	15	18	83	83	10	78	29	69	22	v
CargoBike Cruiser Short Steps	5	3389	3469	-	3745	3629	3905	3985	3699	3975	4055	v	179	-	-68	-65	v	0	10	78	29	69	v	-
CargoBike Classic Long Steps	6	3439	3519	-	3795	3679	3955	4035	3749	4025	4105	v	179	v	15	18	83	83	10	78	29	69	22	v
CargoBike Cruiser Long Steps	7	3439	3519	-	3795	3679	3955	4035	3749	4025	4105	v	179	-	-68	-65	v	0	10	78	29	69	v	-
CargoBike Shadow Steps	8	-	-	-	-	4199	4475	4549	4269	4545	4619	v	179	-	v	3	68	68	v	78	v	40	-	-
CargoTrike Classic Narrow Steps	10	3789	3869	-	4145	-	-	-	4199	4475	4555	v	179	v	15	18	83	83	10	78	29	69	33	v
CargoTrike Cruiser Narrow Steps	11	3889	3969	-	4245	-	-	-	4299	4575	4655	v	179	-	-68	-65	v	0	10	78	29	69	v	-
CargoTrike Classic Wide Steps	12	3839	3919	-	4195	-	-	-	4249	4525	4605	v	179	v	15	18	83	83	10	78	29	69	33	v
CargoTrike Cruiser Wide Steps	13	3939	4019	-	4295	-	-	-	4349	4625	4705	v	179	-	-68	-65	v	0	10	78	29	69	v	-
CargoBike XL met grondplaat	15	-	1804	-	1874	-	-	-	-	-	-	-	v	15	18	83	83	10	78	29	69	22	v+	
CargoBike XL met rek	15	-	1999	-	2069	-	-	-	-	-	-	-	v	15	18	83	83	10	78	29	69	22	v+	
CargoBike Classic Short	16	-	1749	1765	1819	-	-	-	-	-	-	-	v	15	18	83	83	10	78	29	69	22	v	
CargoBike Cruiser Short	17	-	1919	1935	1989	-	-	-	-	-	-	-	-	-68	-65	v	v	10	78	29	69	v	-	
CargoBike Classic Long	18	-	1799	1815	1869	-	-	-	-	-	-	-	v	15	18	83	83	10	78	29	69	22	v	
CargoBike Cruiser Long	19	-	1969	1985	2039	-	-	-	-	-	-	-	-	-68	-65	v	v	10	78	29	69	v	-	
CargoTrike Classic Narrow	20	-	2149	2165	2219	-	-	-	-	-	-	-	v	15	18	83	83	10	78	29	69	33	v	
CargoTrike Cruiser Narrow	21	-	2319	2335	2389	-	-	-	-	-	-	-	-	-68	-65	v	0	10	78	29	69	v	-	
CargoTrike Classic Wide	22	-	2199	2215	2269	-	-	-	-	-	-	-	v	15	18	83	83	10	78	29	69	33	v	
CargoTrike Cruiser Wide	23	-	2369	2385	2439	-	-	-	-	-	-	-	-	-68	-65	v	0	10	78	29	69	v	-	
Riksja	24	-	-	-	-	-	-	-	-	-	-	v	179	v	15	18	83	83	v	78	29	69	-	v
Daycare	25	-	-	-	-	-	-	-	-	-	-	v	179	v	15	18	83	83	v	78	29	69	-	v

Legenda: v = standard on bike, - = not possible option, amount = upprice for option in holland, *1 = only possible on bike with hub dynamo

→ Custom made

You can customise your CargoBike or CargoTrike with most of the upgrade options shown and see on this chart the compatibility with your model.

- **A Bakfiets.nl Cargobike is made in Hoogeveen (Netherlands)**
- **Is the safest way to transport your children with a bike according to ADAC • Easy to ride and manoeuvre**
- **Kids can climb safely in the box because of the solid 4 leg stand**
- **Bakfiets.nl uses FSC approved wood**
- **The box is made from waterproof Phenolic coated multiplex**
- **The powder coating is 3 layers both durable and impact resistant**
- **Stainless steel components are used where possible**
- **Top quality accessories with upgrade options**
- **High resale value due to superb build quality**

